

**ELECTRONIC
SYSTEMS**

(415) 573-7788

564-3111

**HOBBY
COMPUTER
PC BOARDS**

55.30 00 - 40

1 40
2 54

0100 0000

P. O. BOX 212, BURLINGAME, CA

**ELECTRONIC
SYSTEMS**

(415) 573-7788

RS-232

P. O. BOX 212, BURLINGAME, CA

RS 232

DISCRIPTION

The RS 232 board has two seprate circuits. one circuit converts RS 232 to TTL. The other converts TTL to RS 232. The board has a ten pin edge connector. Power requierd, +12V, and -12V.

PARTS LIST

R1 6.8K	C1 100Pf
R2 15K	Q1 2N2222
R3 10K	U1 741-8 pin
R4 15K	D1 1N4148
R5 10K	
R6 15K	
R7 2.7K	
R8 330	

EDGE CONNECTOR

PIN

- 1-GND
- 2-RS 232 in
- 3-TTL out
- 4-+12V
- 5-RS 232 out
- 6--12V
- 7-NC
- 8-NC
- 9-TTL in
- 10-GND

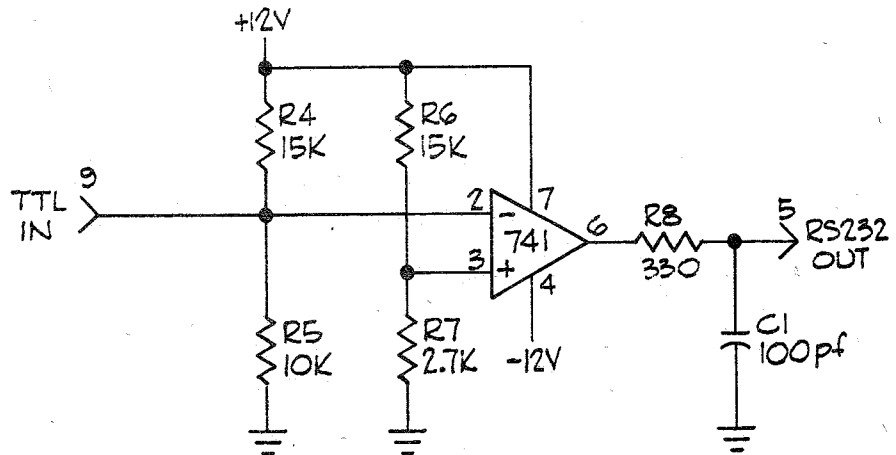
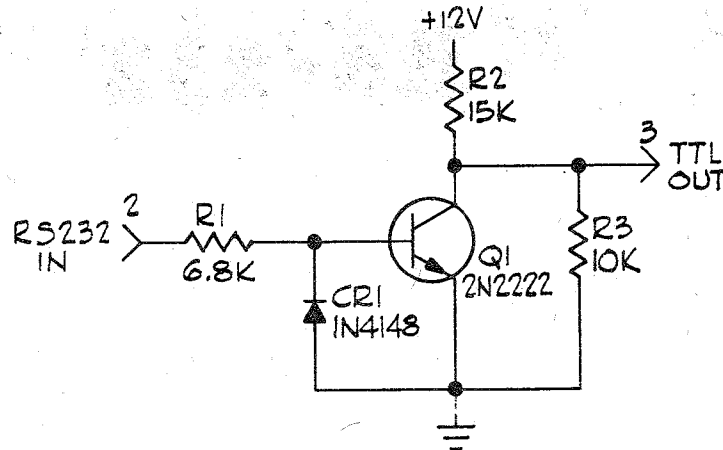
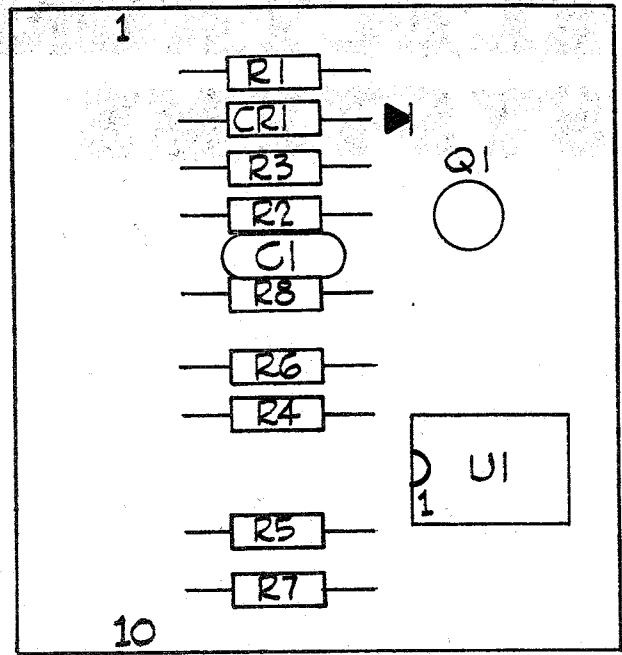

**ELECTRONIC
SYSTEMS**

(415) 573-7788

RF MODULATOR

P. O. BOX 212, BURLINGAME, CA

RF MODULATOR

DISCRIPTION

This circuit converts video to am modulated RF. Channel 2, or 3 can be used. Tuning can be done by bending coil L1. Power is supplied by a 12V center taped transformer.

PARTS LIST

R1 2.2K	C1 .1, 10V	Reg 309H
R2 100	C2 500uF, 25V	D1&2 1N4001
R3 47	C3 30uF, 6V	Q1 2N2222
R4 6.8K	C4 30Pf*	T1 12VAC CT
R5 270	C5 30Pf*	300 mA
R6 1K	C6 270Pf*	
	C7 3Pf*	

All resistors are 1/4 watt, 5%.

*Silver Mica

Coil-3 3/4 turns of 22 AWG wire wound on a no. 2 pencil

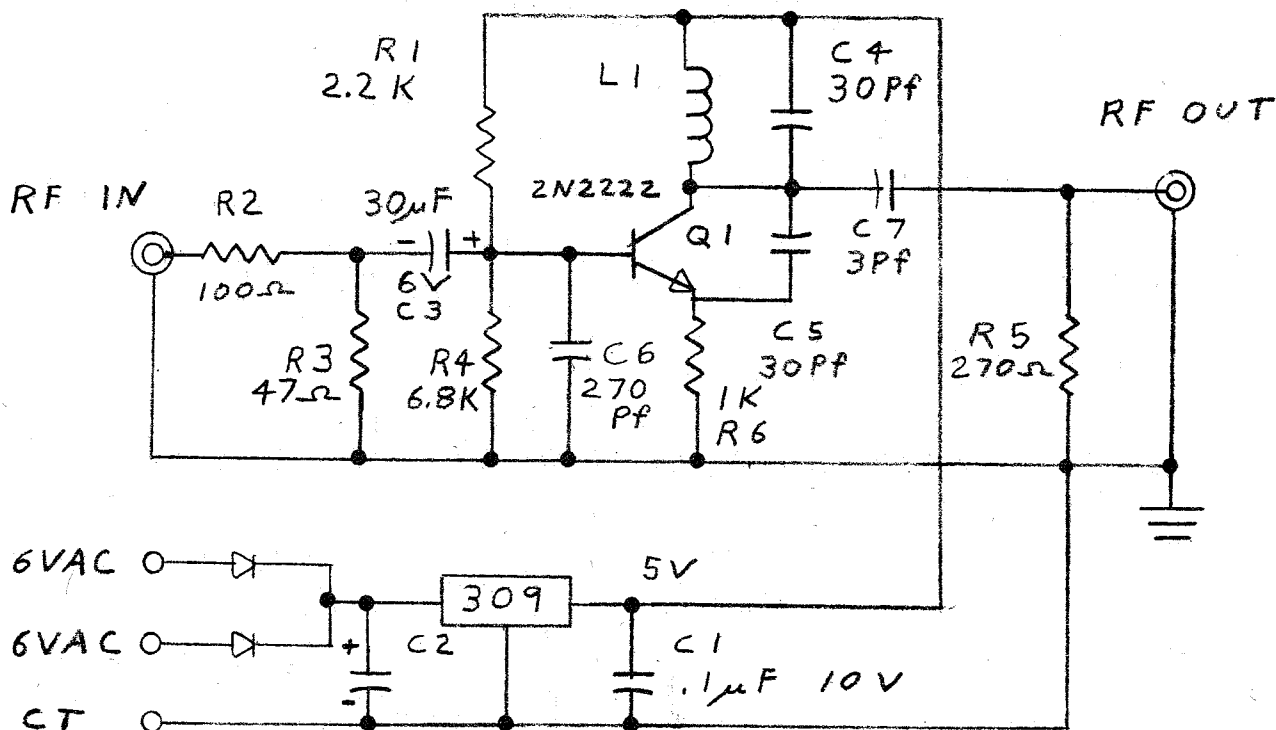
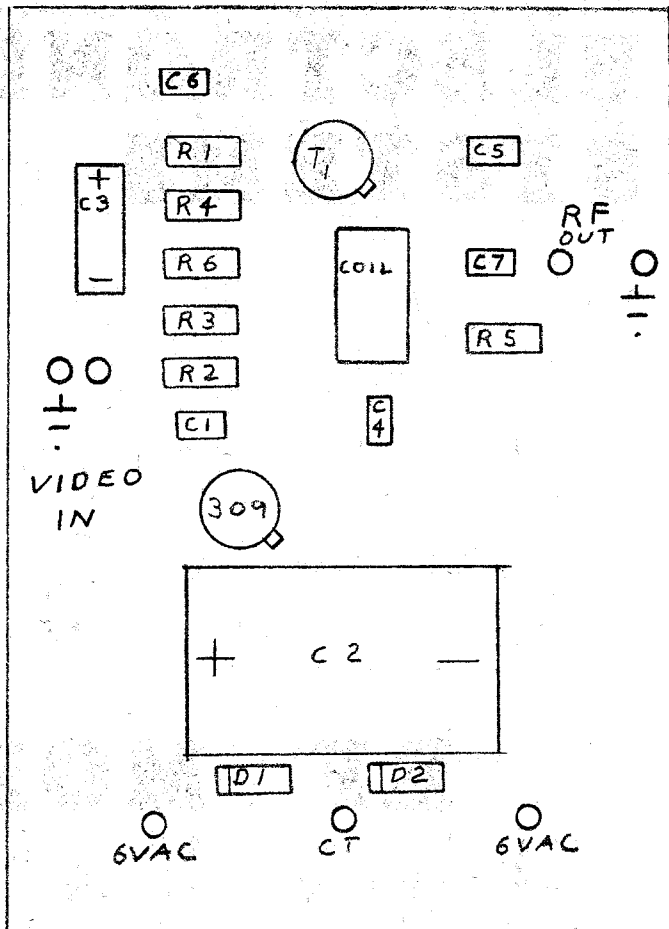

**ELECTRONIC
SYSTEMS**

(415) 573-7788

\$14.95

**UART
&
Baud Rate Generator**

P. O. BOX 212, BURLINGAME, CA

GENERAL DISCRPTION

The Universal Asynchronous Receiver Transmitter (UART) accepts binary characters from either a terminal device or a computer and receives/transmits this character with appended control and error detecting bits. All characters contain a start bit, 5 to 8 data bits, one or two stop bits, and either odd/even parity. In order to make the UART universal, the baud rate, bits per work, parity mode, and the number of stop bits are selectable. All inputs and outputs are directly compatable with TTL/DTL logic without the need for interfacing components and with all strobed outputs having tri-state logic.

The Baud Rate Generator is capable of generating baud rates of 110, 150, 300, 600, 1200, and 2400 that can be selected by an external rotary switch.

The following refers to the 7 - section dip switch:

Switch Number

1. Selects polarity of input strobe pulse. If switch is on, it accepts negative strobe; if switch is off, it accepts positive strobe.
2. Controls the output strobe. On is the positive output pulse, and off is the negative output pulse.
3. Selects odd or even parity bit. On is odd; off is even.
- 4-5. Select the number of bits per character, i.e.:

Sw. 5	Sw. 4	Bits/Char.
ON	ON	5
ON	OFF	6
OFF	ON	7
OFF	OFF	8

6. On selects one stop bit; off selects two stop bits.
7. On selects parity; off selects no parity.

If long leads are used on PIN 15 +16 connect a .001 cap from 15 + 16 to PIN 22 (GND) to eliminate noise

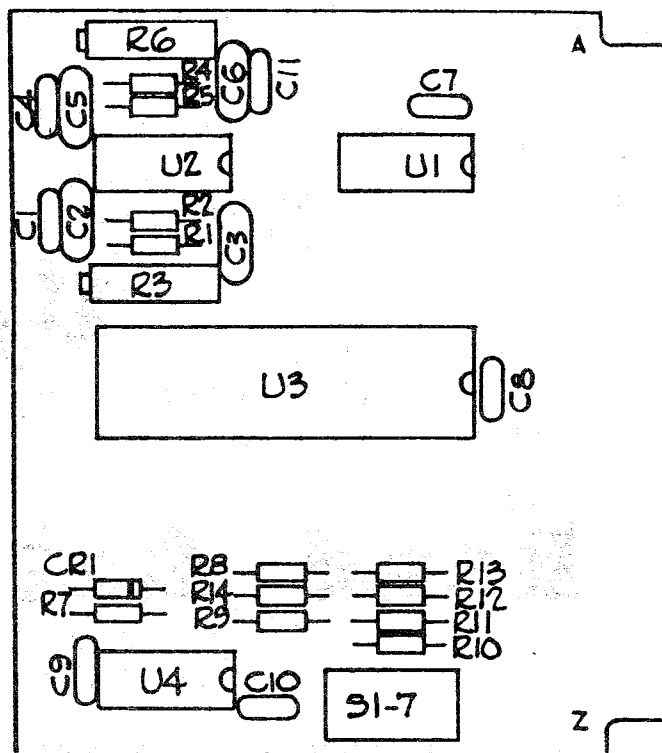

PARTS LIST

U1	74C93
U2	74C04
U3	AY-5-1013A
U4	74C86
S1-7	7 Section Dip Switch
CR1	1N4148
R1,2	220K
R3	100K trim pot, 20 turn, Bourns part no. 3006P-1-104
R4,5	120K
R6	50K trim pot, 20 turn, part no. 3006P-1-503
R5,6	10K
R7	100K
R8-14	10K
C1	910Pf
C2,3	470Pf
C4	82Pf
C5,6	43Pf
C7,C8	0.1uf
C9	.01
C10,C11	.1

Silver Mica, Size DM15

[All resistors are 1/4 watt, 5%]

SCHEMATIC

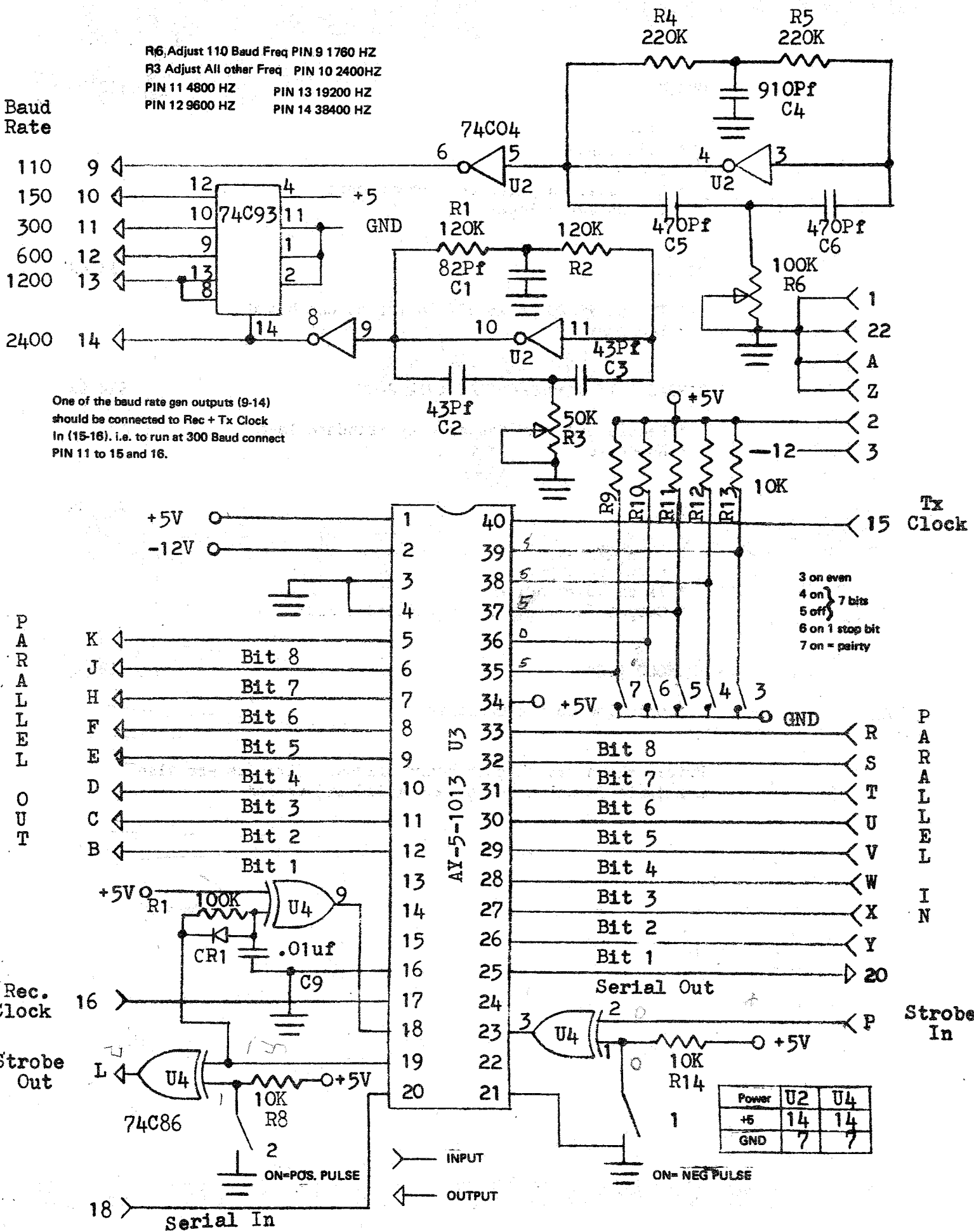

Other circuits available are;

MODEM \$19.95

- * Type 103
- * Full Duplex
- * 300 Baud
- * No coils, only low cost components
- * TTL Output & Input

RS-232 \$3.49

- * TTL to RS-232 & RS-232 to TTL on one board
- * Low cost

KANSAS CITY STANDARD TAPE INTERFACE \$14.95

- * Record and play Kansas City Standard Tapes
- * No coils

TVT \$34.95

- * 32 Char/Line
- * Parallel Input
- * 1K on board memory
- * Output for computer controlled cursor

TV MODULATOR \$8.95

- * Only low cost components

Prices shown are circuit board prices. Circuits are also available in kit form, or assembled and tested.

**ELECTRONIC
SYSTEMS**

(415) 573-7788

TAPE INTERFACE

P. O. BOX 212, BURLINGAME, CA

DISCRIPTION

The Kansas City Standard Tape Interface will convert a low cost tape recorder into a digital tape recorder. This circuit operates up to 300 baud and will play and record Kansas City Standard tapes. Digital in and out are TTL. Output of the Interface connects to the "mic in" of a tape recorder. The "earphone" of the tape recorder connects to the input of the Tape Interface.

ADJUSTMENTS

Adjust R1 for 2400 Hz output with a logic 1 input. Adjust R2 for a logic 1 output with a 2400 Hz input.

PARTS LIST

R1	10K	R12	10K
R2	1M	R13	15K
R3	39K	R14	33K
R4	1M	R15	47K
R5	100K	R16	15K
R6	150K	C1-12	.01 Mylar
R7	1M	C13	10uF
R8	4.7M	U1	LM567
R9	470	U2&3	74C04
R10&11	20K trim pot (Beckman 72PXR20K)		

