

FLEX General Notes

MODIFYING THE MP-A PROCESSOR BOARD FOR FLEX 2.0

If your computer system is a SWTPc and has an MP-A (not MP-A2) processor board, you will have to modify it in order to use FLEX 2.0. The modification allows the CPU to access data from an external memory board rather than the on-board 6810 scratchpad RAM chip. This allows you to use external memory at A000 hex which is where FLEX resides.

The modifications were obtained from Southwest Technical Products engineering staff. If required, power down the system, carefully remove the MP-A processor board (NEVER unplug a board with power on), and make the following modifications:

- 1) Cut the foil trace connecting pin 10 to pin 13 of IC16 on the "TOP" side of the board. IC16 is a 7420 and is the third IC from the left on the bottom row as viewed from the "TOP" side.
- 2) Solder an insulated jumper from the now unconnected pin 13 of IC16 to pin 3 of IC7 on the "BOTTOM" side of the board. IC7 is a DM8097 or a 74367 and is the third IC from the right on the bottom row as viewed from the "TOP" side.
- 3) If you have put IC3 (the 6810 RAM chip) in a socket, simply unplug it. If it is soldered in place, it will be easier to disable it by cutting the foil trace connecting to pin 13 of IC3 on the "BOTTOM" side of the board. Next solder a jumper between pins 12 and 13 of IC3.

The processor board is now ready to be re-installed in your system. Note that the modified processor board will NOT FUNCTION at all without external memory at locations \$A000 thru \$A07F. This is because SWTBUG requires memory in that area. FLEX 2.0 will require memory from \$A000 thru \$BFFF.

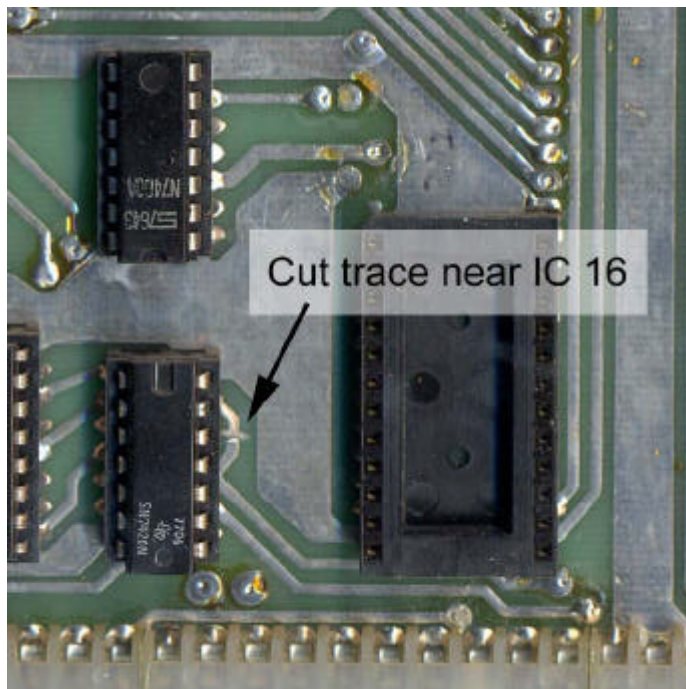

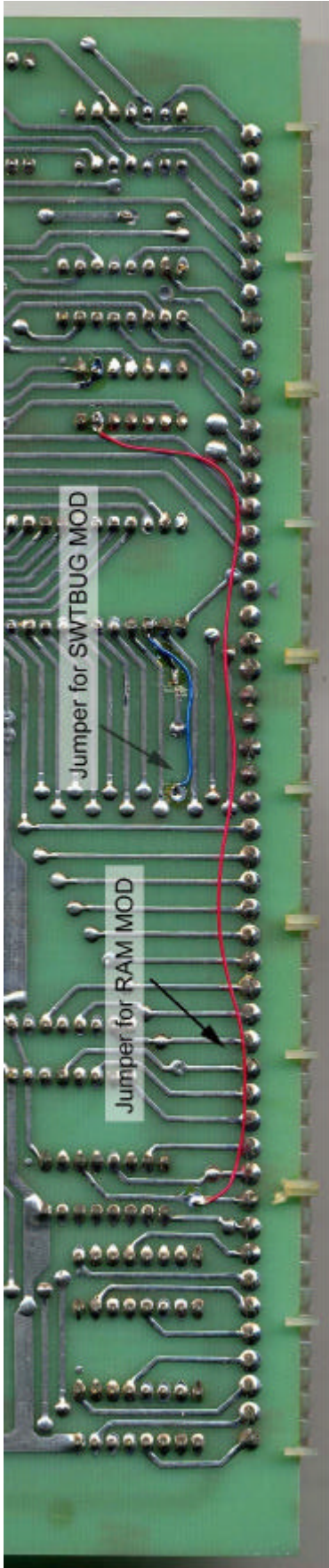

Jumper for SWTBUG MOD

Jumper for RAM MOD